



uGate

Entrance control / Sliding gate

Heras sliding gate uGate provides high security protection at wide span entry ways. A single gate can allow a clear width of 12 metres while a double configuration can achieve a 24 metre opening. A range of heights are available from 1.5 to 2.5 metres.

The strong and lightweight aluminum cantilever design eliminates the need for wheels or tracks which have the potential to be blocked by dirt or snow. This automated or manual operation gate is available in Heracles or Atlas versions (see separate datasheets) with a RAL powder-coating finish.

The uGate is TÜV certified and can be integrated with access control and security options making it the perfect option for ports, high-risk areas, airports, transport and distribution centres, plus military locations.

- **Modular assembly for easy installation**
- **Trackless cantilever design for reliable operation**
- **Single or double configuration – up to 24 metres**
- **Can be integrated with access control and security options**
- **Lightweight aluminum frame available with Heracles and Atlas infill**

Experts in perimeter protection



Drawings (dimensions in mm)

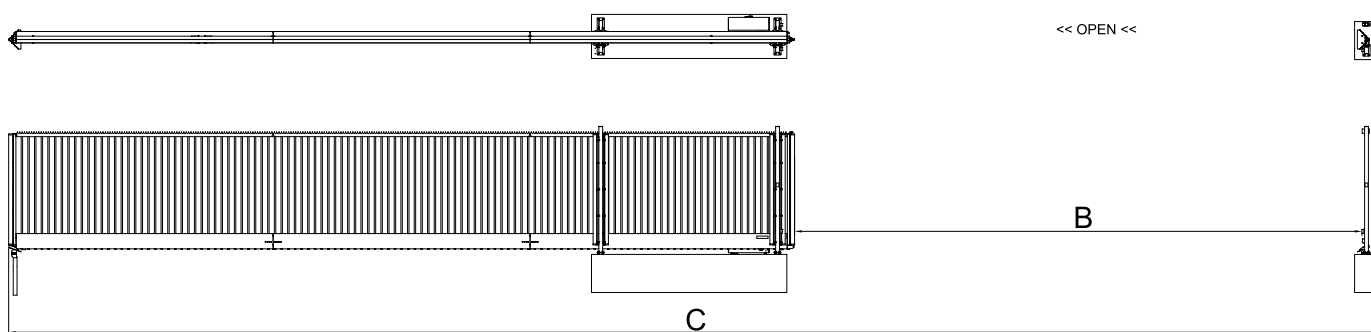

Technical specifications

Type	Single leaf				Double leaf			
	Free opening (B)		Total width (C)		Free opening		Total width	
	Manual	Automated	Manual	Automated	Manual	Automated	Manual	Automated
uGate 70	7075	6930	17200	17210	14205	14090	33860	33965
uGate 80	8075	7930	19600	19610	16205	16090	38660	38765
uGate 90	9075	8930	21720	21730	18205	18090	42900	43005
uGate 100	10075	9930	23840	23850	20205	20090	47140	47245
uGate 110	11075	10930	26520	26530	22205	22090	42500	52605
uGate 120	12070	11925	28775	28785	24195	24080	57010	57115

Heights available (A): 1500, 1800, 2000, 2300, 2500 (2300 and 2500 not available for uGate 120)

Material	Aluminum underbeam with aluminum vertical bar infill
Colour (other colours available upon request)	RAL 6005 (moss green) RAL 6009 (fir green) RAL 7016 (anthracite grey) RAL 9005 (jet black)
Finish	Powder coating (80 µm thick; 80 buchholz hardness)
Leaf	Single or double
Infill	Heracles vertical bars Atlas vertical bars
Drive	Manual or electric motor (see separate HMD datasheet)
Operation time	0.25 or 0.50 m/s

Certificates

- Certificates (CE)
- Declaration of Performance (DoP)
 - Construction Products Regulation (CPR) (305/2011)
 - EN 13241
 - EN 12424 (Wind class 3)
- Declaration of Conformity (DoC)
 - Directives machines (2006/42/EC)
 - EN 13241
 - EMC Directive (2014/30/EU)

Ordering information

Contact your local Heras office for precise ordering details.

Suggested accessories / products

- Heracles bar fencing
- Atlas bar fencing
- Electric fence
- HMD (Heras Motor Drive)